

D

C

B

A

D

C

B

A

UBS PHY Interface (ULPI)

- 5 << HPS_USB_DATA[7..0]
- 5 << HPS_USB_CLKOUT
- 5 << HPS_USB_NXT
- 5 << HPS_USB_DIR
- 5 << HPS_USB_STP
- 6 << CLK_USB_24
- 5,10 << HPS_USB_RESET
- 17 << HPS_USB_RESET_N

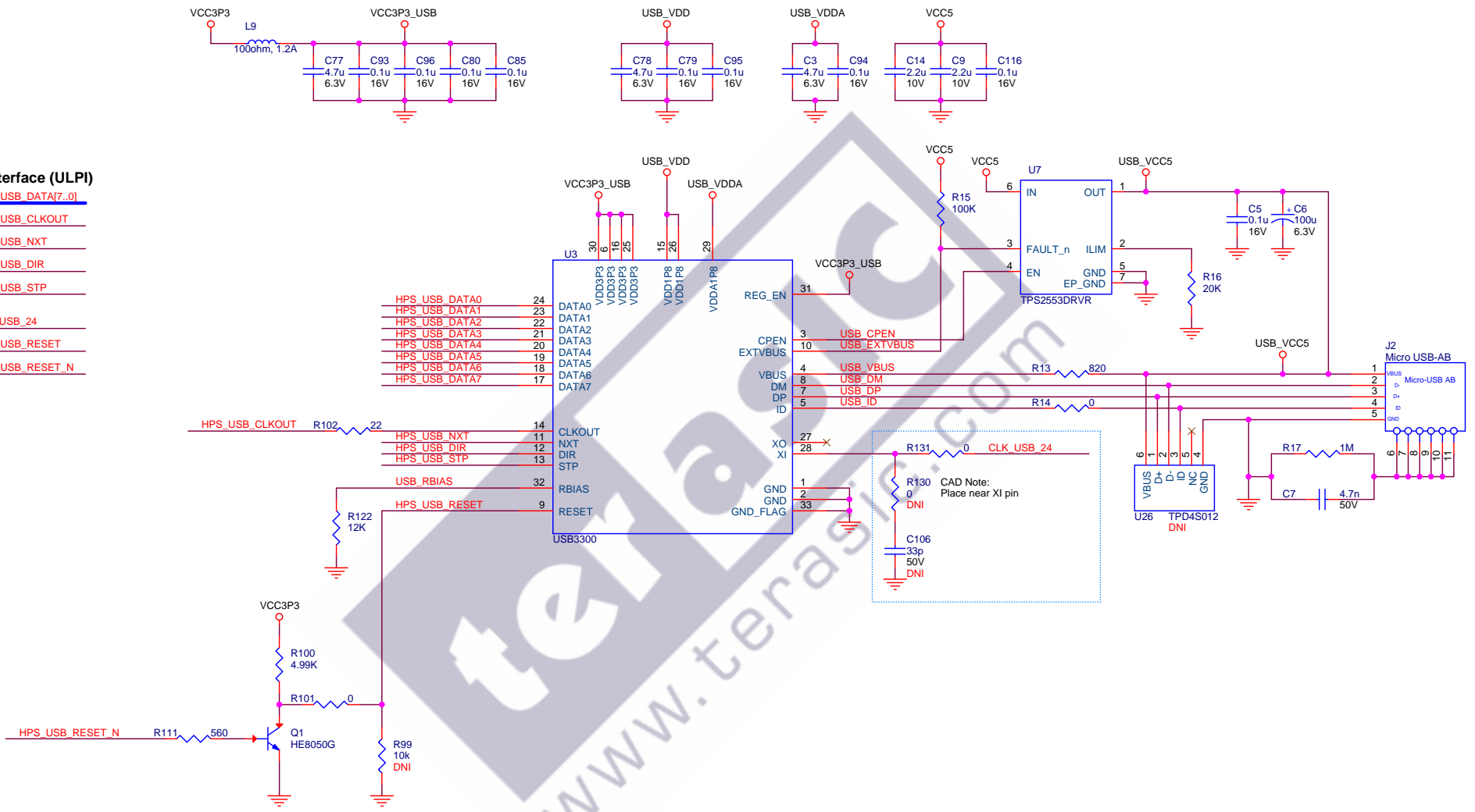

Ethernet PHY Interface (RGMII)

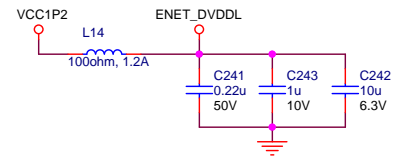
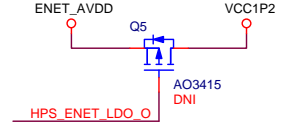
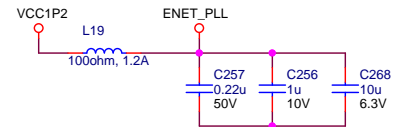
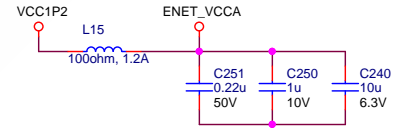
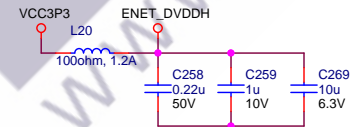
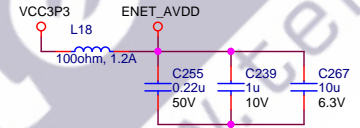
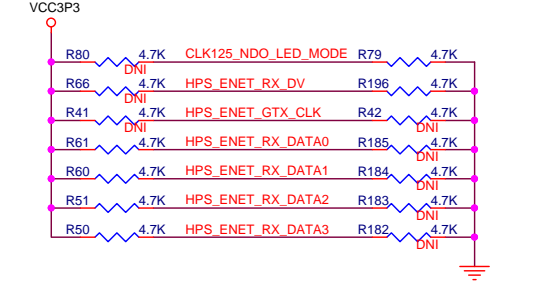
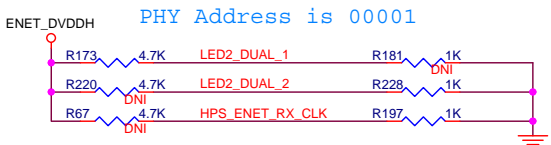
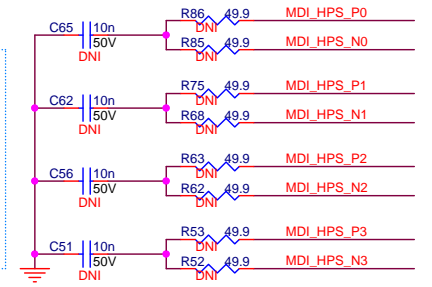
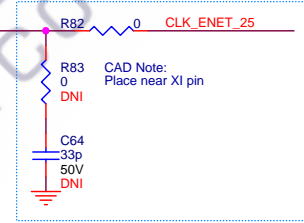
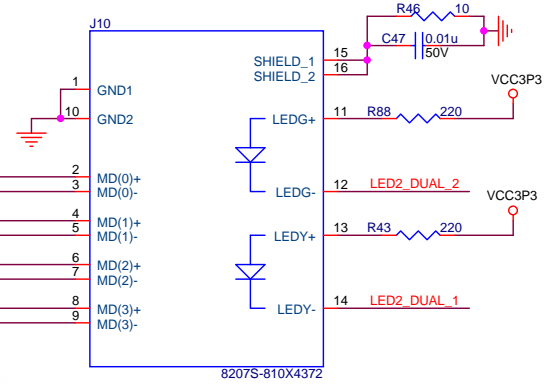
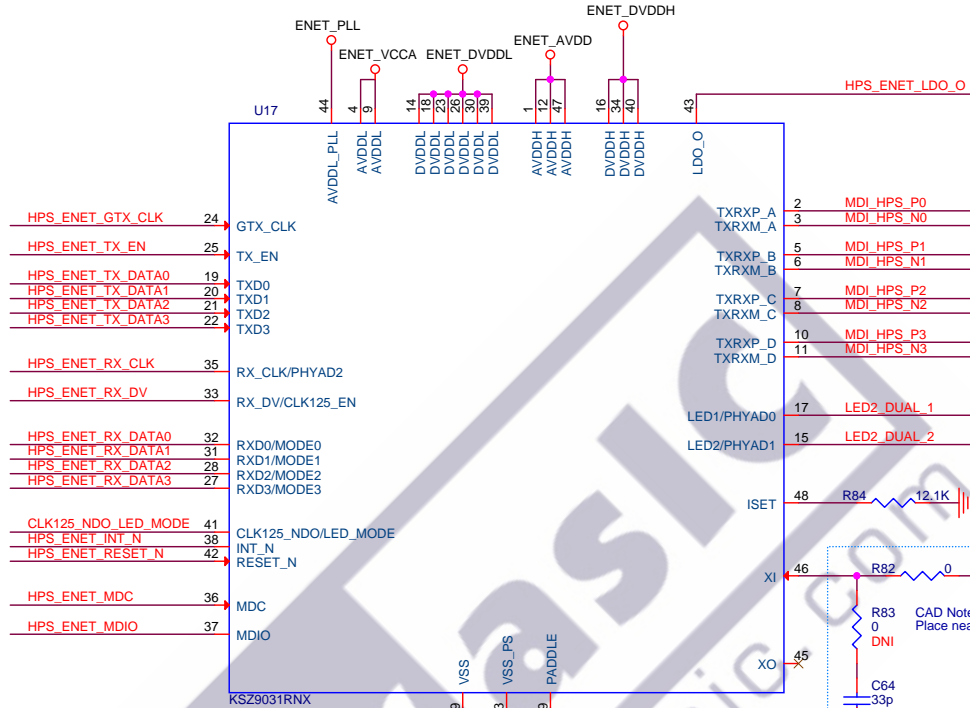
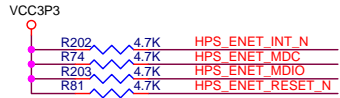
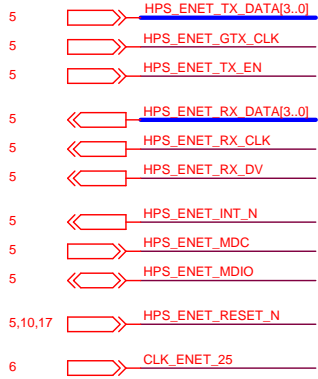

Digital Accelerometer

Accelerometer Interface

- 5 HPS_I2C0_SDAT
- 5 HPS_I2C0_SCLK
- 5 HPS_GSENSOR_INT

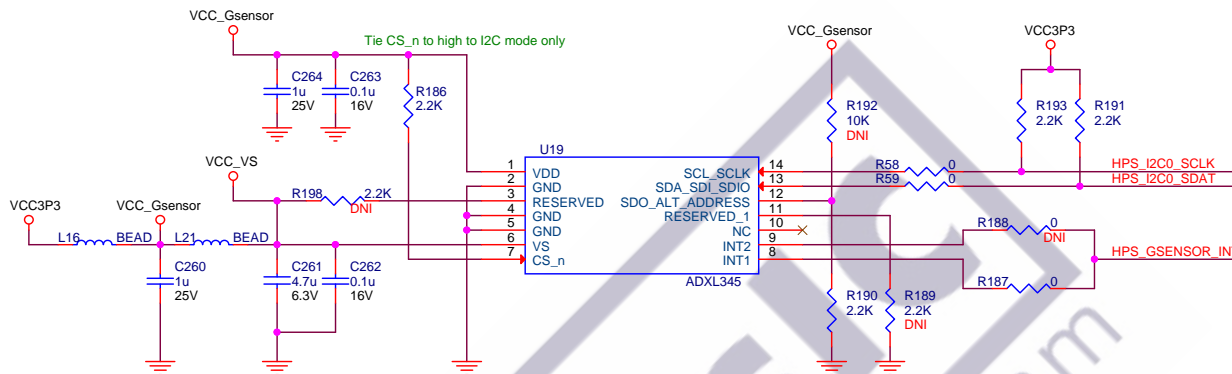

Default : I2C Address 0xA6/0xA7

LTC Interface

- 5 HPS_I2C1_SDAT
- 5 HPS_I2C1_SCLK
- 5 HPS_SPIM_MOSI
- 5 HPS_SPIM_MISO
- 5 HPS_SPIM_CLK
- 5 HPS_SPIM_SS
- 5 HPS_LTC_GPIO

LTC 2x7 Connector

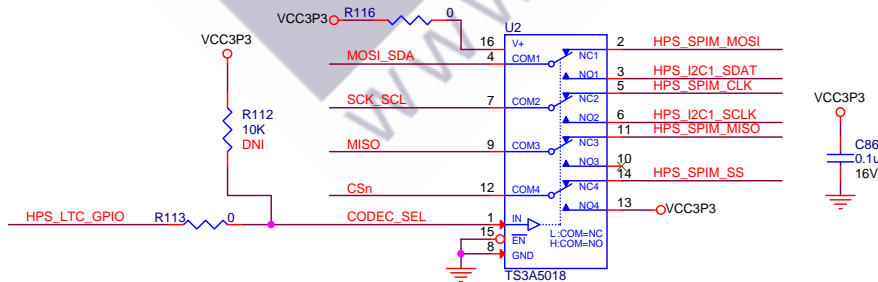
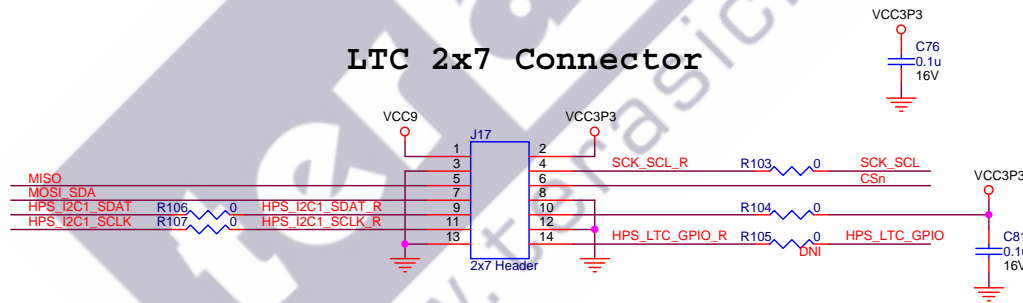

terasic
Copyright (c) 2016 by Terasic Inc. Taiwan.
All rights reserved.
No part of this schematic design may be reproduced, duplicated, or used without the prior written permission of Terasic.

Title		
DE10-Nano Board		
Size	Document Number	Rev
B	HPS : Accelerometer, LTC Connector	A1
Date:	Friday, May 05, 2017	Sheet 16 of 24

HPS Cold Reset

- HPS Cold Reset**
- 5,10 <<> HPS_RESET_N
 - 5,10,15,17 <<> HPS_ENET_RESET_N
 - 13 <<> HPS_UART_RESET_N
 - 14 <<> HPS_USB_RESET_N
-
- 5,10,14 <<> HPS_USB_RESET
 - 5,10,15,17 <<> HPS_ENET_RESET_N
 - 10 <<> COLD_RESET_N
 - 10 <<> KEY_COLD_RESET_N
 - 10 <<> KEY_WARM_RESET_N

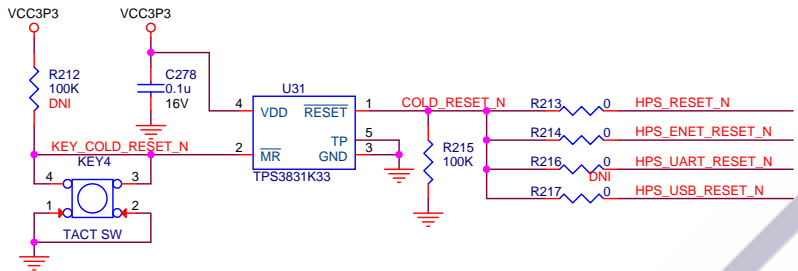

HPS Warm Reset

- HPS Warm Reset**
- 5,10 <<> HPS_WARM_RST_N

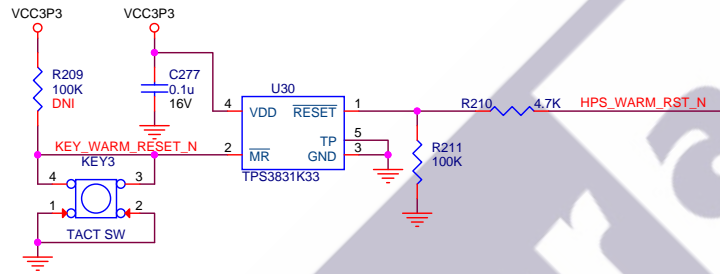

HPS Key and LED

- 5 <<> HPS_KEY
- 5 <<> HPS_LED

HPS User Button

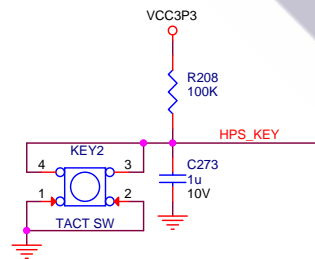

HPS User LED



ADC

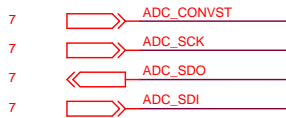

Analog input interface

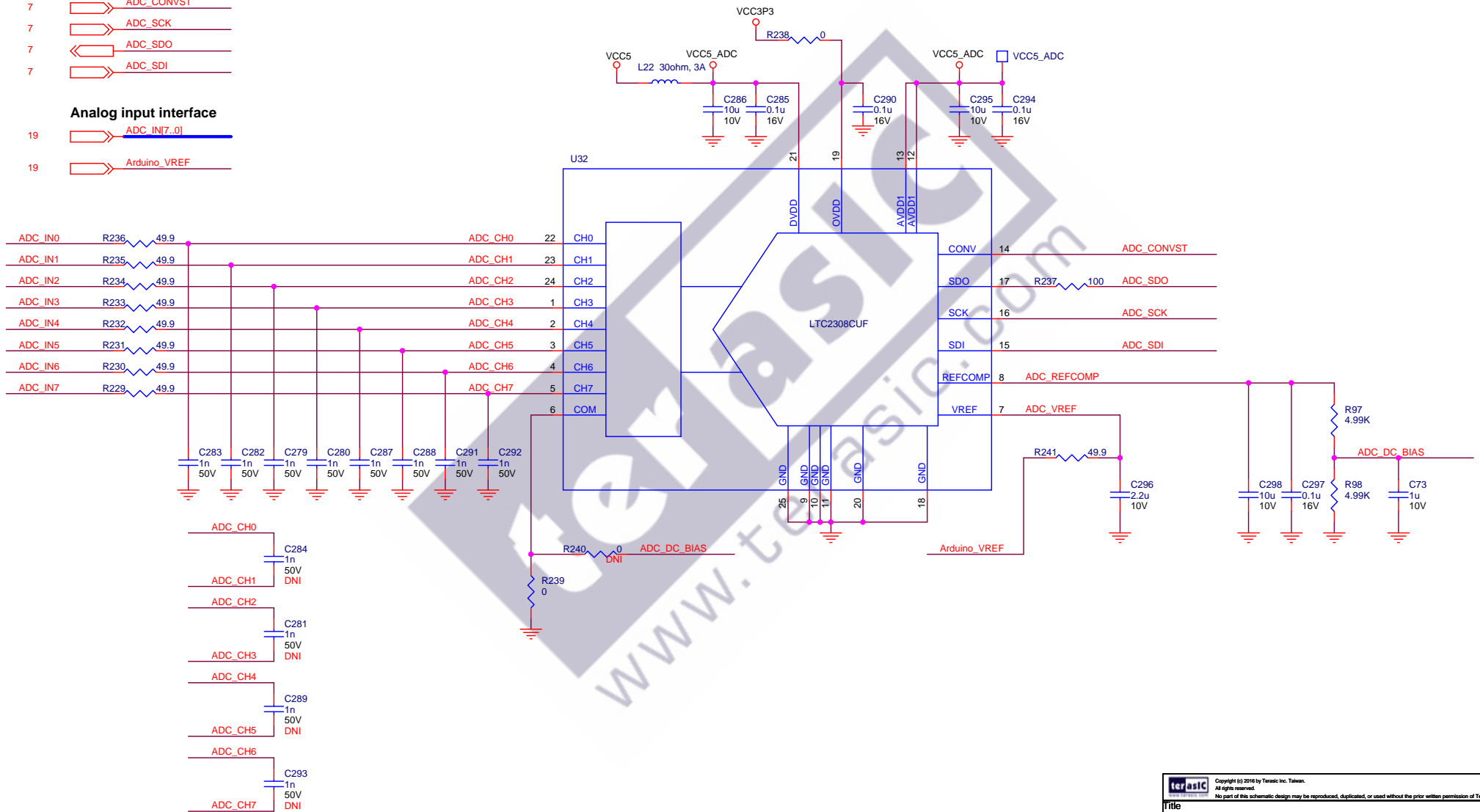

GPIO



Arduino Digital Interface

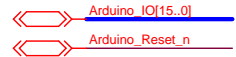

Analog input interface



GPIO 0 Header

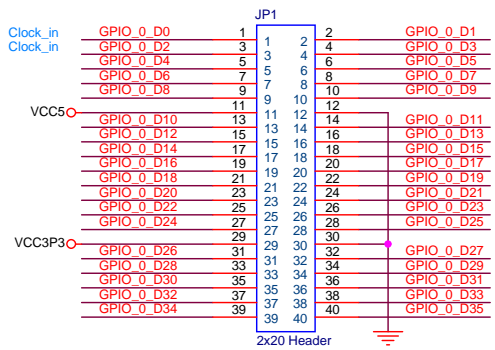

GPIO 1 Header

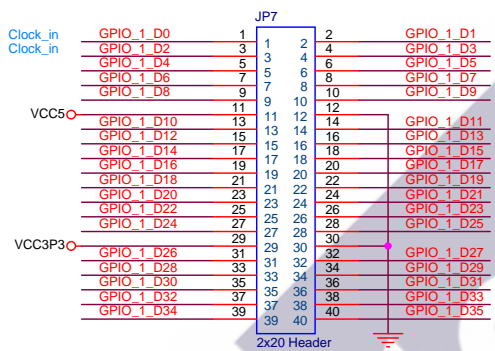

ADC Header

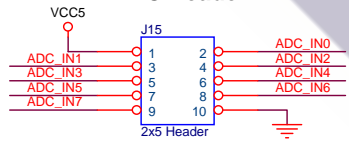

Arduino UNO Rev3

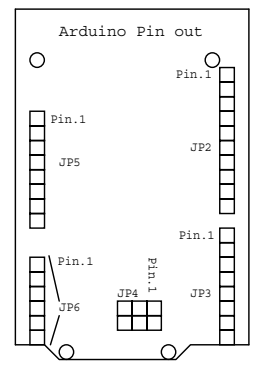
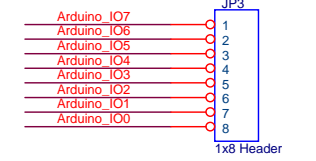
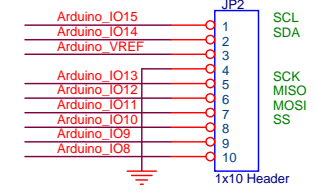
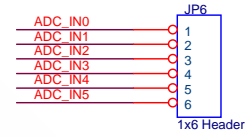
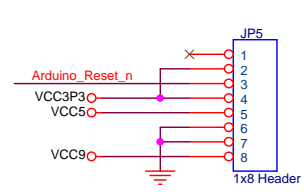
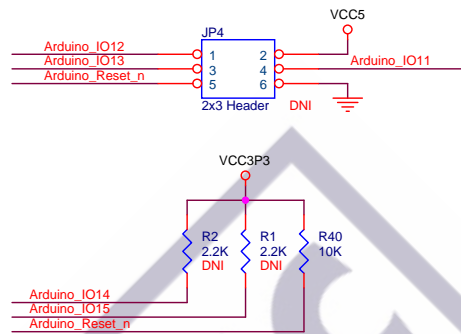

KEY



SWITCH



LED

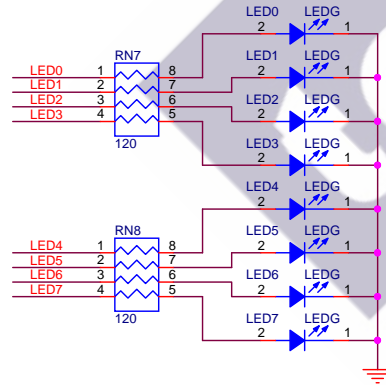
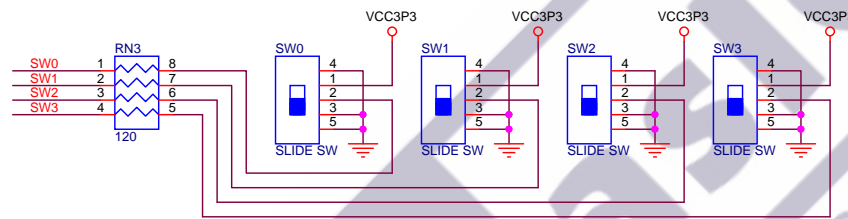
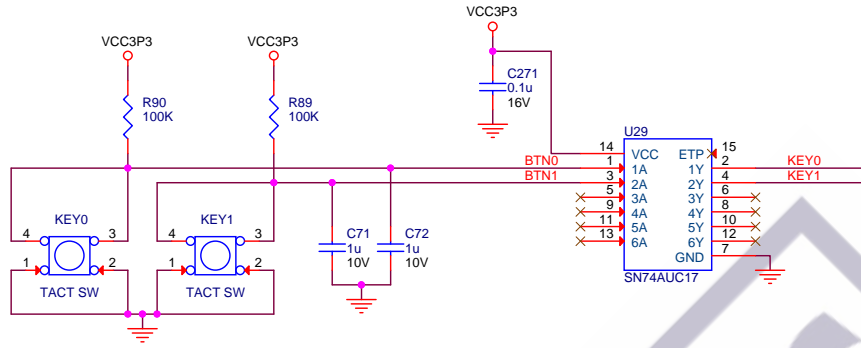

PCB
MPB-3266-B0

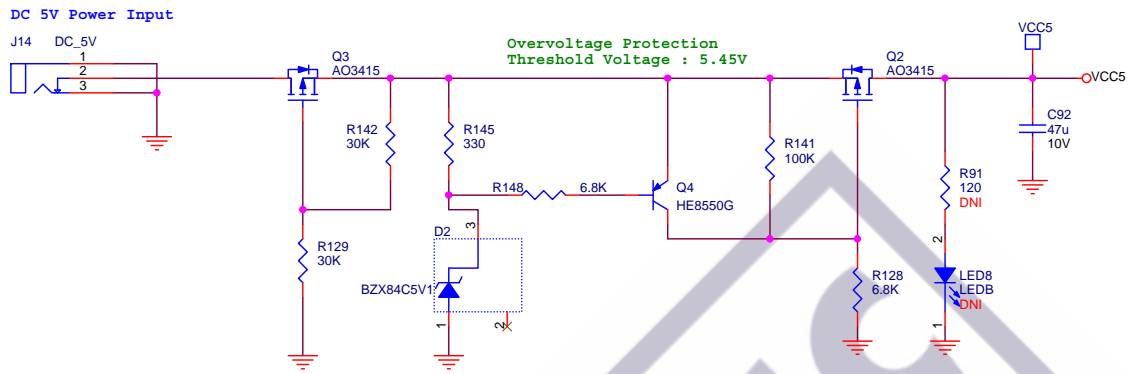

Overvoltage Protection
Threshold Voltage : 5.45V

Ramp Time
Tsoft-start = 1 msec
1.1V / 5.5A

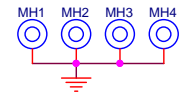
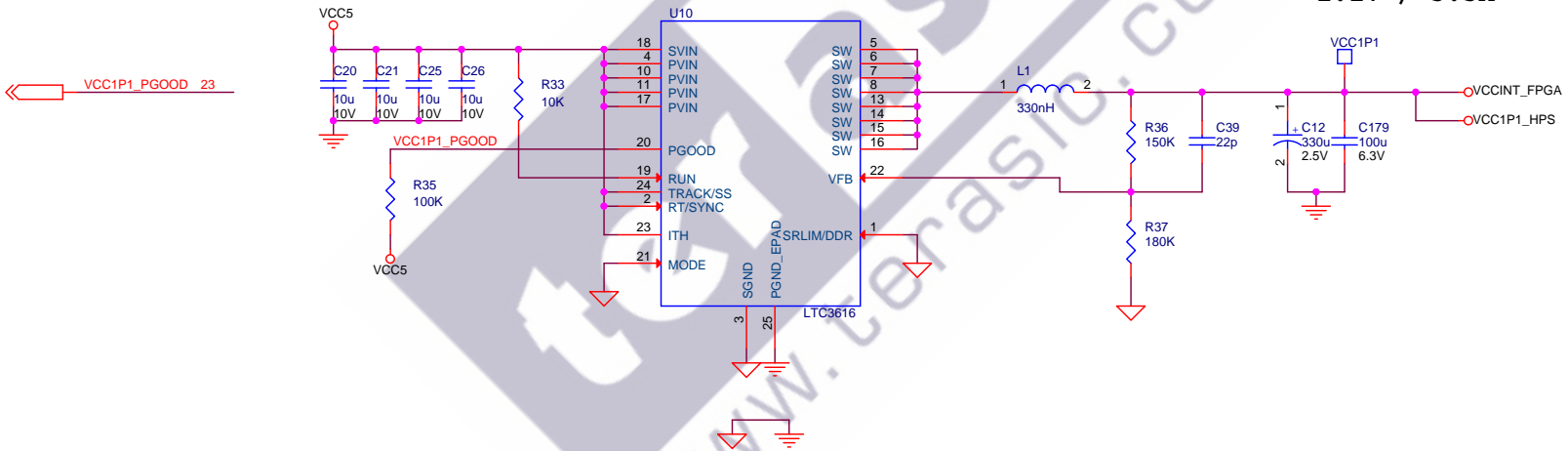

Copyright (c) 2016 by Terasic Inc., Taiwan. All rights reserved. No part of this schematic design may be reproduced, duplicated, or used without the prior written permission of Terasic.	
Title	
DE10-Nano Board	
Size	Document Number
B	Power - 1.1V, 5V
Date:	Rev
Friday, May 05, 2017	A1
Sheet	22 of 24

