

881545-2
881545-2

SHUNT16
SHUNT17

Clock Configuration
Clock Jumpers on...
FPGA A 3-5, 4-6
FPGA B 1-3, 4-6
EXT 3-5, 2-4
NONE 1-3, 2-4

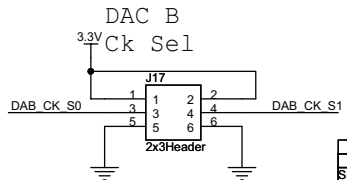
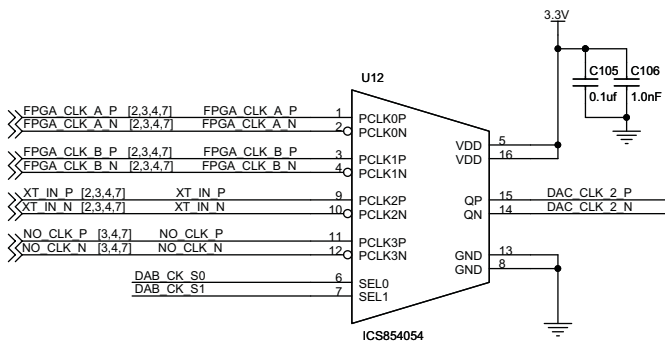
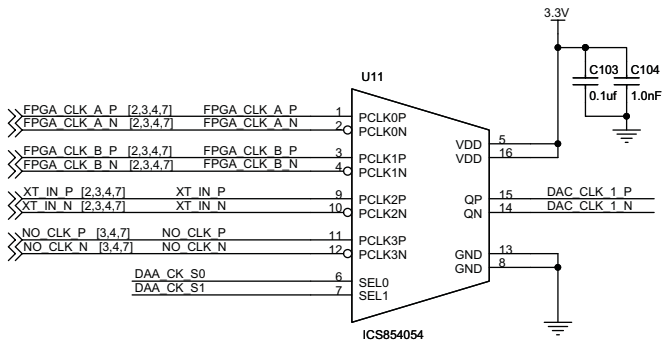
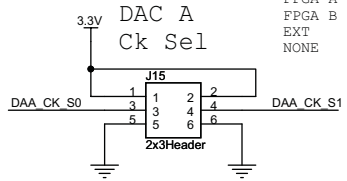

Clock Configuration
Clock Jumpers
FPGA A 3-5, 4-6
FPGA B 1-3, 4-6
EXT 3-5, 2-4
NONE 1-3, 2-4

881545-2
881545-2

SHUNT14
SHUNT15

J10 GSET
J11 MODE
J13 SLEEP

881545-2
881545-2
881545-2

SHUNT11
SHUNT12
SHUNT13

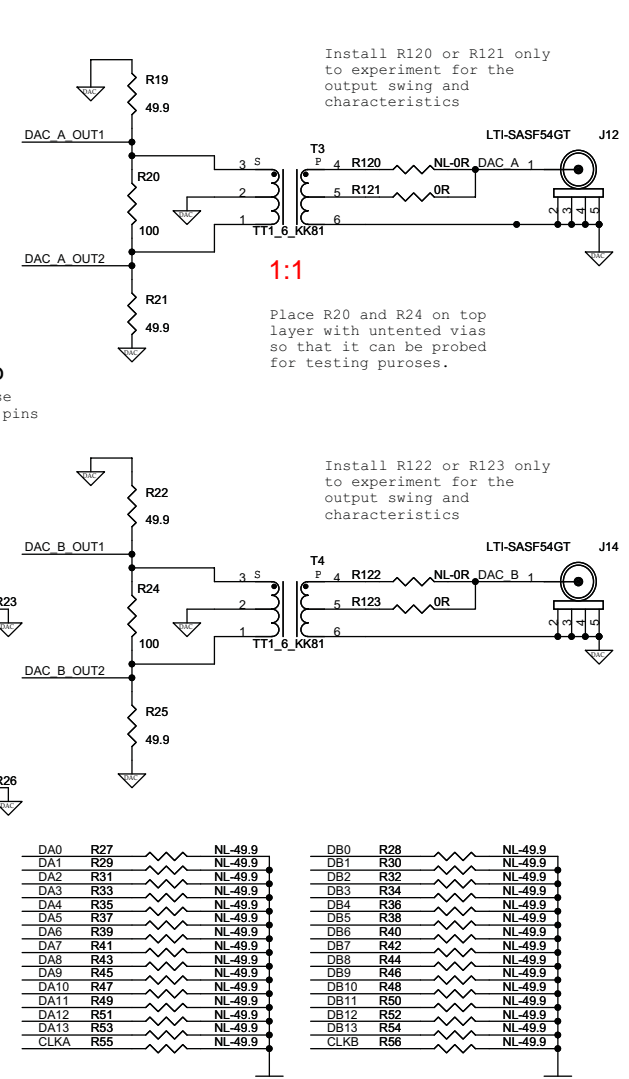
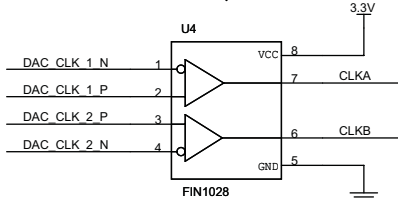
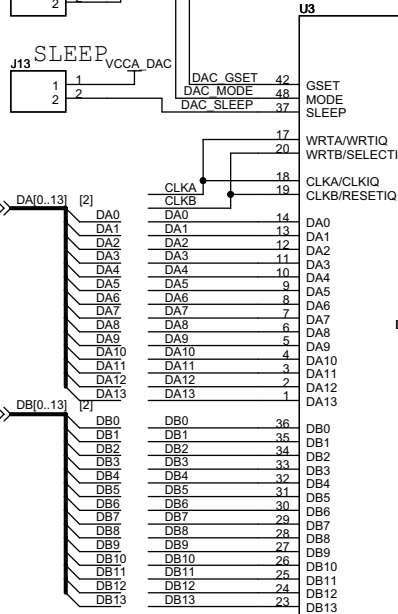

Altera Corp, Santa Cruz Technology Center
110 Cooper St, Suite 201, Santa Cruz, CA 95060

Title: **Data Conversion HSMC**

Size: Custom	Document Number: P06-18227R	Rev: 0A
--------------	-----------------------------	---------

Date: Monday, January 28, 2008 Sheet 5 of 8